

Voicebox 4 I/O Overview

The Voicebox 4 I/O CobraNet Audio Interface is a cost effective 4 in/4 out mic/line preamp. The Voicebox 4 I/O features 4 balanced inputs, with both gain and +12V phantom power selectable on a per channel basis, and 4 line level balanced outputs. All outputs can contain any mix of local and network audio inputs. An RS-232 port enables the transmission of serial data from any Voicebox 4 I/O to any other CobraNet device supporting a serial bridge connection on a CobraNet system.

Applications

- Adding additional inputs or outputs to an existing CobraNet system
- Complete small to medium systems
- OEM applications with custom DSP processing

Features

- Full CobraNet connectivity in a half-rack format
- Fully balanced inputs and outputs with high quality depluggable connectors
- +12V Phantom Power, switchable per channel
- Input gain selection for line (0dB), electret mics (+30dB), and dynamic mics (+50dB)
- DSP audio signal processing on inputs and outputs. For OEM applications, Atterotech can implement custom signal processing
- RS-232 connector for transmission of serial data between Voicebox 4IOs using CobraNet serial bridging
- Enclosure size is 1.5"H x 7.25"W x 6.5"D

VoiceBox 4 I/O Front and Rear Panels

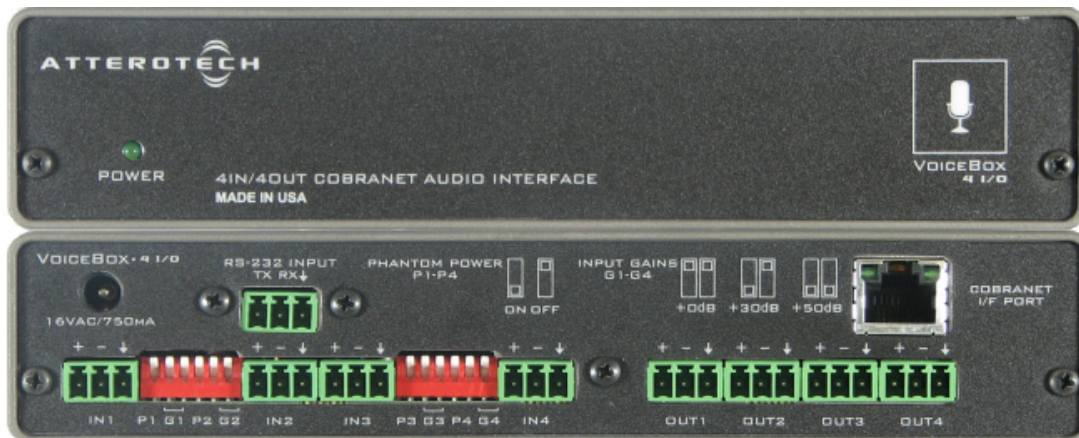

CobraNet® is a registered trademark of Cirrus Logic, Inc.

VoiceBox 4 I/O Block Diagram

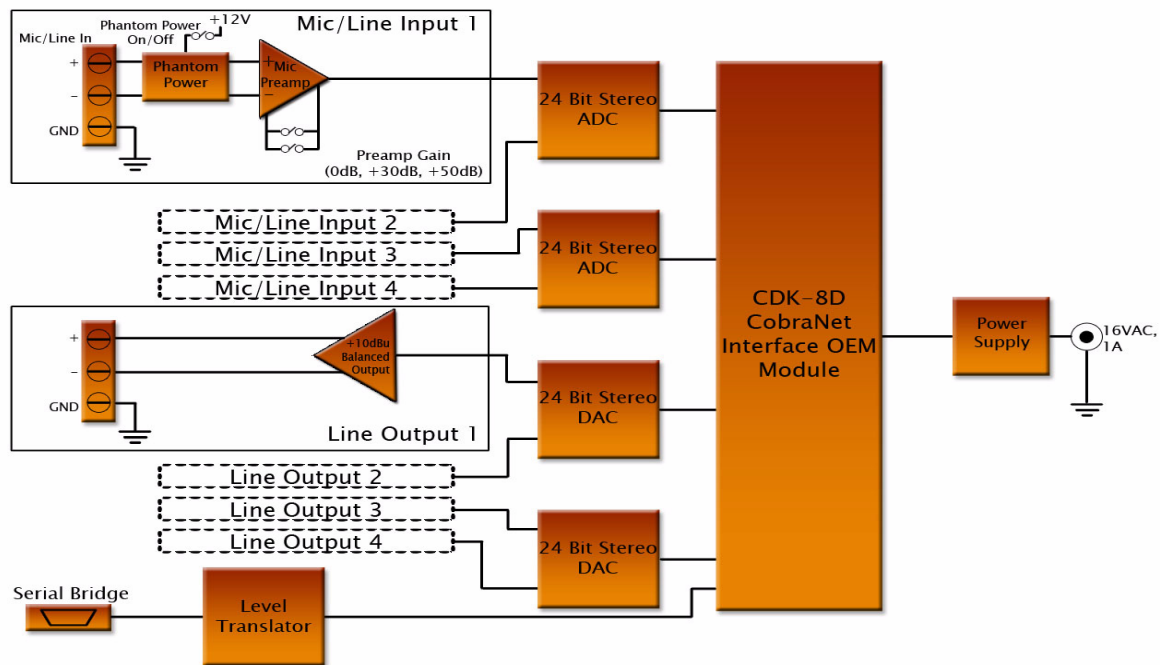

Specifications in Brief:

Mic/Line Input Type:	Balanced and RF filtered
Input Impedance:	> 1.5K Ω , any gain
Input Gain Settings:	0dB, +30dB, +50dB
EIN, 20–20kHz:	-127dBu (+50dB gain)
Maximum Input Levels:	+6dBu @ 0dB gain, -27dBu @ +30dB gain, -44dBu @ +50dB gain
Output Type:	Balanced with automatic muting upon loss of CobraNet signal
Output Impedance:	200 Ω balanced, 100 Ω unbalanced
Noise:	< -83dBu @ 0dB gain
Maximum Output Level:	+10dBu
System THD:	< 0.1% at any gain, inputs signal 3dB below maximum
Phantom Power:	+12V (selectable per channel)
RS-232:	RX, TX, and ground at standard RS-232 levels
Power Consumption:	12 Watts maximum @ 16VAC
Dimensions:	1.5" H x 7.25" W x 6.5" D

Architects & Engineers Specification

The CobraNet interface unit shall provide four mic/line analog inputs on rear panel pluggable 3-pin barrier strips. Selectable gain of 0dB, +30dB, +50dB, and +12V phantom power shall be provided on rear panel DIP switches for each analog input channel. The internal analog to digital signal conversion shall be performed at 16-, 20-, or 24-bit resolution with a sampling frequency of 48kHz. Eight channels of CobraNet inputs and eight channels of CobraNet outputs are supplied via the rear panel RJ-45 connector. Four channels of balanced line-level outputs shall be provided on the rear panel pluggable barrier strips.

The CobraNet interface shall provide DSP capabilities for independent channel gain, equalization, and compression on all four local input channels. Each local output channel shall have DSP output limiting capabilities. The DSP shall also provide a fully configurable 13-input, 12-output matrix mixer with an input from a configurable sine wave generator.

The CobraNet interface shall be compatible with Attero Tech Control Center software for flexible control and monitoring in system applications. The CobraNet interface shall include a UL listed power source. The CobraNet interface shall be compliant with RoHS directive.

The CobraNet interface shall be the Attero Tech VoiceBox 4 I/O.